

# ECOSURE 2 DRUM SPILL PALLET

Ref: ECO2DRUM/PE

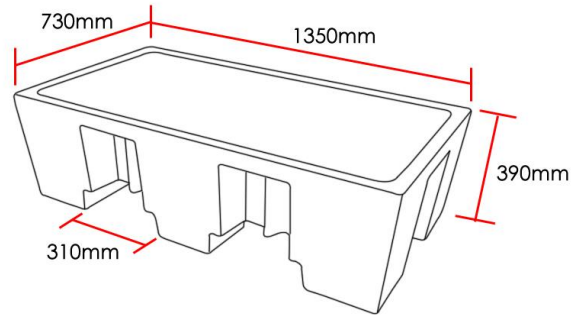

**10 YEAR GUARANTEE  
FREE DELIVERY\***

\* Exclusions apply

The Ecosure 2 Drum Spill Pallet will help you to comply with the current oil and chemical storage regulations. Specially constructed to support heavy loads, it is ideal for the long term safe storage of standard 205 litre drums. Made entirely from polyethylene, it is suitable for use with all oils and most non-combustible chemicals. In the event of a leak, fluid is contained in the sump, preventing contamination to the environment.

#### Why buy Ecosure spill pallets?

- Tough construction
- Retains long term structural integrity
- Forkliftable for easier handling
- 10 year guarantee
- Free delivery

#### Benefits

- Protects the workplace, environment and personnel
- Designed for the safe storage of 205 litre drums
- Maintenance free

#### Compliance

- Compliant with the 110% bund regulations
- No drainage points to compromise the bund area

Material:	MDPE
External dimensions:	H: 390mm x W: 730mm x L: 1350mm (NOTE: dimensions approximate, owing to shrinkage)
Regulation capacity:	225.5 litres
Actual capacity:	225.5+ litres
Standard colour:	Yellow with black grid Available in other colours at an additional cost

#### Product features:

- Low profile makes loading easy
- Made of 100% polyethylene with the latest UV stabilisation package
- 2 way forklift entry
- Sturdy grid which is removable for easy cleaning and will not rot like wood

As the UK manufacturer, we offer quality products at competitive prices. Should you receive a more competitive like-for-like quotation, we guarantee to beat it.

**To order call: 01763 261781**



Etills Ltd  
Unit 1 Whiting Way,  
Melbourn, Royston,  
SG8 6NA

Tel: 01763 261781  
Fax: 01763 268409